



Care and Cleaning.

OMNIplus

Services for your Mercedes-Benz and Setra

Name: Cleaning and care instructions
Language: ENG
Edition: 03.05.2017
Order no.: A 628 584 92 16

EvoBus GmbH
D-89231 Neu-Ulm
Germany

© EvoBus GmbH 2017

Not to be reprinted, reproduced or translated, in whole or in part, without prior permission.

Document organisation	1		
The use of symbols and their meanings	1		
General information	3		
Directions for care and cleaning	4		
Interior	7		
Covers and upholstery	8		
Stain types, treatment advice	9		
Fabric covers	10		
Flat-weave fabric upholsteries	13		
Leather covers	15		
Needle-punched nonwoven fabrics	18		
Micro-fibre covers	19		
Ceilings	21		
Ceiling, TC 500	22		
Floor coverings	24		
Exterior	27		
Instructions for exterior washes	28		
Exterior washes in an automatic vehicle wash	29		
Headlamps	30		
Light-alloy wheels	31		
Bottom	33		
Underbody	34		
Axles with compact bearings	38		
Windows	39		
Interior/exterior	40		
Index	41		

The use of symbols and their meanings

The use of symbols and their meanings

Safety precautions and other important information are highlighted by symbols.

In addition to the instructions provided herein, all generally applicable safety and accident prevention regulations must also be observed, e.g. in Germany, the rules and regulations of the institutions for statutory accident insurance and prevention.

Where information and instructions are to be observed, it is assumed that the user information contents are intended only for persons who are suitably qualified to carry out the tasks by nature of their education, training and experience.

These persons should, at the same time, be able to identify risks that may arise in the undertaking of their tasks and take the necessary measures to avoid them.



Helpful information

Denotes tips and additional information as follows:

	Tip
	Note



Physical and environmental damage

Denotes types of damage, possible consequences and instructions on how to avoid them.

	Physical damage
	Environmental damage



Warning notes

Denotes hazards, possible consequences and instructions on how to avoid them.

	DANGER. Warning note indicating the presence of a hazard that could lead to death or serious injury.
	WARNING. Warning note indicating the presence of a hazard that could lead to some form of injury.

Symbols and structure guide

Denotes written texts

	Action to be performed
	Expected response of the system after an action
	List with any sequence

Directions for care and cleaning 4

Directions for care and cleaning

Directions for care and cleaning

Note

Regular care of the vehicle makes a crucial contribution to value retention.

Danger

Risk of poisoning caused by the incorrect use of cleaning and care products.

- ▶ Observe the information on the cleaning and care products.
- ▶ Do not use any diesel, regular or premium fuels for cleaning.
- ▶ After use, always keep cleaning and care products sealed and stored correctly out of the reach of children.

Warning

Risk of injury from incorrect handling of the high-pressure cleaner. Incorrect handling poses a danger to your own health and safety and that of other persons and animal life.

- ▶ Observe the manufacturer's instructions.

- ▶ Do not aim the water jet at human beings or animals.
- ▶ Be mindful of the water temperature, especially if the water is hot.
- ▶ Select the appropriate spraying attachment for the intended purpose as recommended in the manufacturer's information.
- ▶ Allow only briefed and competent persons to have access to the high-pressure cleaner.

Caution

Physical damage caused by the use of a high-pressure cleaner or steam cleaner, occurring as visible defects in the material or concealed defects in the structure. Structural damage eventually leads to unforeseeable material failure. This could consequently result in hazardous situations in road traffic.

- ▶ In the interior, do NOT use any high-pressure cleaner or steam cleaner.
- ▶ In the engine compartment, do NOT aim the spray jet DIRECTLY at belt tensioners or idler pulleys.

- ▶ In the underbody, do NOT use a high-pressure cleaner in combination with a round-spray jet or dirt blaster.
- ▶ Do not aim the high-pressure jet directly at tyres, suspension air bags, brake hoses, hose connections made from rubber, gaiters, the bearings of moving parts, or electrical lines or components and their connections.
- ▶ Keep the high-pressure water jet moving at all times and vary its direction across the surfaces to be cleaned.
- ▶ Do NOT use any high-pressure cleaner or steam cleaner in the region of axle seals (e.g. hubs, drive flange) and axle breathers.
- ▶ Do NOT use round-spray jets to clean tyres and suspension air bags.

**Caution**

Physical damage caused by the use of unsuitable cleaning agents incompatible with components such as rubber hoses. Damaged components eventually lead to unforeseeable material failure. This could consequently result in hazardous situations in road traffic.

- ▶ Do NOT use acetone in the engine compartment or on components containing rubber.
- ▶ Do NOT use any cleaning agents containing vinyl chloride in the engine compartment.
- ▶ The laws and regulations of the country in which the bus is operated must be observed. Comply with safety rules and regulations, accident prevention regulations and environmental legislation. Implement work safety measures.
- ▶ Read and observe the instructions for the care and cleaning products before use.
- ▶ Observe disposal requirements for empty containers, cleaning cloths and polishing wads, etc.
- ▶ Cleaning the interior: Make sure that no fluid enters or is left behind in gaps and cavities. Allow the vehicle interior to dry completely. Ensure adequate aeration and ventilation while cleaning work is taking place.
- ▶ We recommend that only tested and approved care products should be used. Information about acceptable care products can be obtained from your OMNIplus Service Partner.
- ▶ In winter, wash the vehicle more frequently in order to remove salt residues from road gritting.
- ▶ To avoid paint damage: Remedy impurities such as insect remains, bird droppings, tree resins, oils and greases, fuels or tar stains without delay using acceptable cleaning agents.
- ▶ To avoid rust: Clean chip damage to paint caused by stone impact without delay and repair it in a professionally correct manner.

Covers and upholstery 8
Stain types, treatment advice 9
Fabric covers 10
Flat-weave fabric upholsteries 13
Leather covers 15
Needle-punched nonwoven fabrics 18
Micro-fibre covers 19
Ceilings 21
Ceiling, TC 500 22
Floor coverings 24

Covers and upholstery

Covers and upholstery

Special notes on care and cleaning of covers and upholstery

Note

Observe the information about your upholstered furnishings and covers contained in the detailed description of the bus.

Caution

Physical damage caused by the use of solvent-based cleaning agents on fabric covers and furnishings made of plastic or foam.

- ▶ Do NOT use acetone, petroleum ether, alcohol or any other solvent-based cleaning agents.
- ▶ Use only pH-neutral cleaning agents.
- ▶ Use approved cleaning agents for the cover material concerned.
- ▶ Use distilled water to avoid limescale stains.

- ▶ Remove dirt as soon as possible to avoid permanent stains or damage.

Stain types, treatment advice

Stain type	Treatment
Fruit juice, soft drinks	Washing-up liquid pH neutral
Lemonade	Washing-up liquid
Beer	Washing-up liquid
Milk	Washing-up liquid
Blood	Cold water
Felt-tip pen, marker pen	Washing-up liquid, soap solution
Lipstick	Washing-up liquid
Shoe polish	Washing-up liquid, soap solution
Butter, oil and grease	Washing-up liquid, soap solution
Nail varnish	Washing-up liquid, soap solution
Ball-point pen, inks	Washing-up liquid, soap solution

Fabric covers

Fabric covers

i Note

Regular care and basic cleaning help to maintain the value and high-quality appearance of fabric covers. For this reason, carry out basic cleaning regularly. Carry out basic cleaning more regularly if necessary, depending on use and the level of dirt.

i Note

To order wet cleaners and obtain further information, go directly to the suppliers Kärcher or Miryam Alt:

Fa. Alfred Kärcher

Internet: <http://www.kaercher.com/de/>

Fa. Miryam Alt Busequipment GmbH

Internet: <http://www.miryam-alt.com>



M58.40-0034-71

1. **Kärcher** Puzzi system



M58.40-0061-71

2. Spray **Extraktionsgerät** Nil Fix

Caution

Physical damage caused by the use of solvent-based cleaning agents on fabric covers and furnishings made of plastic or foam.

- ▶ Do NOT use acetone, petroleum ether, alcohol or any other solvent-based cleaning agents.
 - ▶ Use only pH-neutral cleaning agents.
 - ▶ Use approved cleaning agents for the cover material concerned.
 - ▶ Use distilled water to avoid limescale stains.
 - ▶ Remove dirt as soon as possible to avoid permanent stains or damage.
3. Observe the safety information in the “Directions for care and cleaning” (→ page 4) section.
 4. Minimise exposure to direct sunlight to avoid colour fading.
 5. Do NOT use hard brushes.
 6. Do NOT use sharp-edged vacuum nozzles. Do NOT use rubber vacuum

nozzles or vacuums with rubber attachments.

- Do not use very rough sponges or cloths.

Mixing cleaning agents

- Observe the user instructions issued by the manufacturers.

Required material	
Kärcher RM 770 intensive cleaner	QEV111AD074I
Surfactant-free cleaning agent	QEV111AD0WPX



M91.18-0001-81

- For light dirt, apply the cleaning agent evenly using a spray gun (2) and leave it to work for approximately five minutes.
- For heavy dirt, apply the cleaning agent repeatedly and leave it to work.
- Fill the wet cleaner with water in accordance with the manufacturer's instructions.



M58.40-0062-71

- Use the upholstery adapter (2) of the manufacturer.
- Clean the seat covers twice using the wet cleaner.

Reference values	
Water temperature	20 ... 40 °C
Water flow per minute	≤ 1 ℓ

Fabric covers

Note

Then rub the seat covers dry using a white, absorbent cloth against the nap of the fabric.

Note

For heavy dirt, repeat the entire cleaning procedure.

3. Do not apply directly to the seat fabric.
4. Do not rub.
5. Do not use hard brushes or other cleaning aids.

Removing stains

1. If the seat covers still show dirt or stains after wet cleaning, they can be treated with a stain remover.



Warning of damage to property

Not applicable to fabric type “flat-weave fabric upholsteries”! For this fabric type, please refer to the separate cleaning information.

2. Apply the stain remover to a soft cloth and treat the dirt.

Required material

Stain remover QEV111AD0WPS

Flat-weave fabric upholsteries

Flat-weave fabric upholsteries

**Danger**

Risk of poisoning caused by the incorrect use of cleaning and care products.

- ▶ Observe the information on the cleaning and care products.
- ▶ Do not use any diesel, regular or premium fuels for cleaning.
- ▶ After use, always keep cleaning and care products sealed and stored correctly out of the reach of children.

**Note****Stain removal**

Refer to the “Overview of stain type / treatment advice” section.

**Note****Flat-weave fabric upholsteries**

Flat-weave fabrics are a relatively new type of fabric construction in the bus division. They differ from the familiar velour fabrics not only in their appearance, but also in the way they should

be treated and used. The differences in their properties impact directly on the user, i.e. the bus operator.

Flat-weave fabrics have an innovative, modern look and combine well with many kinds of material. They are very robust, easy to maintain and can usually be cleaned without any trace being left behind. Although the cleaning interval is shorter than that for velour fabrics, this is ultimately beneficial to hygiene.

This upholstery material is also characterised by the fact that stains and impressions left by an occupant's body show up quickly, and it is very sensitive to solvent-based cleaning agents (particularly in the case of flocked material). Regular cleaning is essential to preserving a maintained appearance and keeping it looking as good as new.

**Note****Cleaning notes**

Soiling may occur in the form of stains caused during use, e.g. by drink and food spills, road grime or similar. In most cases, these can be removed straightforwardly with regular dry or wet cleaning. To keep the flat-weave fabric upholstery in the best possible condition, it is necessary to clean the fabric regularly. We make the following recommendation for cleaning intervals:

- Dry cleaning once a week.
- Basic cleaning (see below) as required or at least every 6 months

Cleaning step 1

1. Dry cleaning by vacuuming (e.g. seats) with a dry vacuum cleaner.

Cleaning step 2

1. Wet cleaning with a commercially available wet vacuum appliance. Exerting gentle pressure, work the seat squab padding from back to front and

Flat-weave fabric upholsteries

the backrest from top to bottom. The padding should be wet all over by the end of the treatment in order to avoid the formation of outlines.

Cleaning step 3

1. Then leave the padding to dry for a suitable period, depending on ambient temperature, but for at least 24 hours.



Tip

Notes on optimum care

Many stains are removed effectively by soap solution or washing-up liquid. Never use cleaning agents containing solvents. These could be unkind to flat-weave fabric upholsteries. Similarly, strong rubbing should be avoided. Please work with a circular motion, otherwise the fabric could be damaged.

Impregnation



Note

To improve the anti-stain performance of flat-weave fabrics, these upholsteries can be treated with an FC impregnating agent (fluorocarbon). This must not be sprayed on **until after** the **drying phase** stated under **cleaning step 3**.



Note

The textile protectant should be sprayed on neat. The protectant is colourless and odourless and does not affect the colours of the textiles.

Good air circulation should be ensured at the time of application. The roof hatches, the doors and, if applicable, the windows of the bus should be opened. The textile protectant must not come into contact with the eyes. Protective gloves and a respirator mask must also be worn. Further information and safety precautions are stored in BusDoc.

The user information issued by the manufacturer of the textile protectant must be strictly observed.



Note

All cleaning agents needed for vehicle interior aftercare can be obtained from authorised OMNIplus Service Centres. The advisers there will be happy to answer any questions.

Leather covers

**Warning of damage to property**

To avoid leaving chalky outlines or water marks, use only distilled water for cleaning.

**Warning of damage to property**

Minimise exposure to direct sunlight to avoid colour fading.

**Note**

Regular care and basic cleaning help to maintain the value and high-quality appearance of leather covers, as well as the long-term durability and suppleness of the leather. For this reason, carry out basic cleaning at least four times a year. Carry out basic cleaning more regularly if necessary, depending on use and the level of dirt.

Basic cleaning - every quarter

1. Remove coarse dirt with a very soft brush or a vacuum cleaner.

**Warning of damage to property**

Do not use a sharp-edged vacuuming nozzle or too hard a brush, otherwise you could damage the leather beyond repair.

2. Moisten a soft, lint-free cloth with distilled water.
3. Wipe leather upholstery down with a damp cloth.

**Warning of damage to property**

Do not use a cloth or sponge with a rough surface as this could scratch the leather upholstery or damage it beyond repair.

**Warning of damage to property**

The leather covers must be completely dry before they are sat on again, otherwise permanent pressure marks could form.

Removing stains**Warning of damage to property**

Remove dirt as soon as possible to prevent permanent stains or damage to the covers.

1. Remove as much dirt as possible using a soft, lint-free cloth.
2. Gently work a mild, lukewarm soap solution into the dirty area.

Required material

“Allrein Seife” pH-neutral soap
QEV111AC6JMY (1 l)

**Note**

Only use pH-neutral soap.

3. Then wipe the dirt up using a clean cloth.
4. Remove the soap solution used using clean, distilled water.

Leather covers

Note

All dirt and soap residues must be completely removed. If in doubt, rinse again.

Note

To avoid the formation of outlines, not only should the mark be treated but also the wider area around it.

- Then dry the cleaned areas using a hairdryer set to medium heat, keeping it moving in a circular motion at a distance of 30 cm to 40 cm.



Warning of damage to property

The leather covers must be completely dry before they are sat on again. Permanent pressure marks could otherwise form.

- If the stains are still visible after cleaning with soap solution, they can be treated using a leather cleaning agent.

Note

Always observe the user information issued by the manufacturer of the cleaning agent.

- Moisten a soft, lint-free cloth with cleaning agent, apply to the leather and remove the stain.

Required material

“Colourlock Lederreiniger Mild” leather cleaning product
QEV111AC6JM8

“Colourlock Lederreiniger Stark” leather cleaning product
QEV111AC6JNA

Note

For more stubborn stains, use the “Lederreiniger Stark” intensive leather cleaning agent.

Note

Allow the leather upholstery to dry fully before repeated applications.

Note

The leather upholstery must be re-sealed whenever the leather has been cleaned or stains have been removed (refer to “Care of leather”).

Care of leather

Note

To protect against wear and soiling, leather upholstery should be sealed whenever general cleaning has taken place.

Note

Always observe the user information issued by the manufacturer of the sealing agent.

- Moisten a soft, lint-free cloth with sealing agent and apply to the leather.

Required material

“Colourlock Leder Versiegelung” leather care product

QEV111AC6JOB

“Colourlock Protector” leather care product

QEV111AC6JNC

**Note**

Treat older leather upholsteries with “Colourlock Protector” leather care product.

Needle-punched nonwoven fabrics

Needle-punched nonwoven fabrics

Special notes on daily care and cleaning

Note

Refer to the “Overview of stain type / treatment advice” section

1. Remove loose, visible dirt using a soft, long-bristle brush or a vacuum cleaner with low-friction plastic nozzle.

Note

Pick up loose dirt by hand, do not rub the dirt.

2. Dab up fresh stains, where possible, immediately using a sponge or absorbent cloth.
3. Dissolve old stains by treating them with lukewarm water and a delicate detergent, always working from the outside in, and soak up with a sponge.

Special notes on intermediate cleaning and particularly heavy soiling

1. Perform intermediate cleaning using a vacuum cleaner in conjunction with a low-friction plastic nozzle (dry).
2. Remove beer, brandy, milk, fruit juice, coffee, jam, red wine and tea immediately using a delicate detergent and an absorbent sponge.
3. Dab up greasy stains using a clean cloth and treat the cleaned area with a delicate detergent and liquid stain remover.

Micro-fibre covers

Note

Regular care and basic cleaning help to maintain the value and high-quality appearance of micro-fibre and wool covers. For this reason, carry out basic cleaning regularly. Carry out basic cleaning more regularly if necessary, depending on use and the level of dirt.

Basic cleaning - weekly

1. Vacuum the covers along the nap of the fabric, without applying pressure.



Warning of damage to property

Do not use rubber vacuum nozzles or rubber attachments. These could pull threads out of the upholstered covers.

2. Using a soft brush, gently brush the upholstery down along the nap of the fabric.

Basic cleaning - every six months

1. First carry out the weekly basic cleaning.
2. Work up a foam from a mild, lukewarm soap solution (e.g. from a mild-action detergent).
3. Apply the foam evenly over all the covers using a soft, slightly damp sponge.
4. Wait until the freshly cleaned covers are completely dry.



Warning of damage to property

The covers must be completely dry before they are sat on again. Permanent pressure marks could otherwise form.

5. Brush along the nap of the fabric using a soft brush, without applying pressure.

Removing stains

Note

Refer to the “Overview of stain type / treatment advice” section



Warning of damage to property

Remove dirt as soon as possible to prevent permanent stains or damage to the covers.

1. Remove as much dirt as possible using a lint-free cloth.
2. Using a soft sponge, work a mild, lukewarm soap solution into the dirt in circular movements from the outside in. Exert gentle pressure in the process.



Note

Always clean up the dirt from the outside in to prevent it from being dispersed in the fabric.

Micro-fibre covers



Warning of damage to property

Do not use cleaning products containing solvents (e.g. petroleum ether, acetone, alcohol, etc.). This would damage the micro-fibre covers and equipment parts made of plastic or foam beyond repair.

3. Mop up the soap solution using a clean, soft sponge.
4. Wait until the freshly cleaned areas are completely dry.



Warning of damage to property

The covers must be completely dry before they are sat on again. Permanent pressure marks could otherwise form.

5. Finally, brush the cover and the cleaned areas using a soft brush along the nap of the fabric.



Warning of damage to property

If in any doubt, use a professional textile cleaning company.

Ceilings

**Caution**

Physical damage caused by the use of solvent-based cleaning agents on fabric covers and furnishings made of plastic or foam.

- ▶ Do NOT use acetone, petroleum ether, alcohol or any other solvent-based cleaning agents.
 - ▶ Use only pH-neutral cleaning agents.
 - ▶ Use approved cleaning agents for the cover material concerned.
 - ▶ Use distilled water to avoid limescale stains.
 - ▶ Remove dirt as soon as possible to avoid permanent stains or damage.
1. Observe the safety information in the “Directions for cleaning and care” section.
 2. Do NOT use hard brushes.
 3. Do not use very rough sponges or cloths.

Removing stains

1. Remove as much dirt as possible using a lint-free cloth.
2. Using a soft sponge, work a mild, lukewarm soap solution into the dirt in circular movements from the outside in. Exert gentle pressure in the process.

**Note**

Always clean up the dirt from the outside in to prevent it from being dispersed in the fabric.

3. Mop up the soap solution using a clean, soft sponge.
4. Wait until the freshly cleaned areas are completely dry.
5. Finally, brush the cover and the cleaned areas using a soft brush along the nap of the fabric.

**Tip**

If in any doubt, use a professional textile cleaning company.

Ceiling, TC 500

Ceiling, TC 500



Caution

Physical damage caused by the use of solvent-based cleaning agents on fabric furnishings of the ceiling panelling.

- ▶ Do NOT use acetone, petroleum ether, alcohol or any other solvent-based cleaning agents.
- ▶ Use only pH-neutral cleaning agents.
- ▶ Use distilled water to avoid limescale stains.
- ▶ Remove dirt as soon as possible to avoid permanent stains or damage.



Caution

Physical damage caused by the breakdown of fire-resistant properties in the event of extensive cleaning or washing.

- ▶ Confine the removal of stains to small areas only, check for colour fastness beforehand.
- ▶ Do not wash the fabric, whether by machine wash or by hand.

- ▶ In case of widespread dirt, the ceiling panelling will need to be replaced with new panelling.



M68.00-0657-76

- 1 Ceiling panelling (headliner)
 - 2 Side cover strips of ceiling panelling
 - 3 Roof hatch/emergency exit/roof ventilation flap
 - 4 Folding monitor
- ▶ Read and observe the instructions for the care and cleaning products before use.



Warning of damage to property

Before cleaning, the interior surfaces and the passenger seats must be suitably covered for protection.

- ▶ Observe disposal requirements for empty containers, cleaning cloths and polishing wads, etc.
- ▶ No fluids must be allowed to enter or be left behind in gaps and cavities. Allow the vehicle interior to dry completely. Ensure adequate aeration and ventilation while cleaning work is taking place.

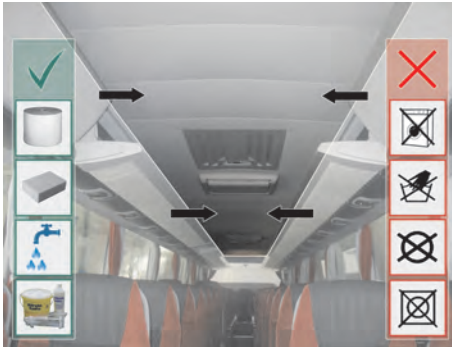

M68.00-0658-76

- ▶ Remove the dirt carefully using a pH-neutral soft soap and plenty of water. Repeat the cleaning process if necessary.
- ▶ Use only white and lint-free cloths or a sponge.

Required material
“Allrein Seife” pH-neutral soap QEV111AC6JMY (1 ℓ)
“Allrein Seife” pH-neutral soap QEV111AC91M5 (10 ℓ)

Floor coverings

Floor coverings



Warning of damage to property

These instructions refer exclusively to spray-on or bonded floor linings (not carpets or fabric linings).



Note

With light dirt, it is sufficient to perform cleaning with a broom, vacuum cleaner or clean water. The floor coating has a rough texture due to the coloured glitter in the surface. For wet cleaning, it is therefore advisable to work with a soft brush.



Note

The use of cleaning agents that contain solvents or have a pH value of below 6 (acid) or higher than 10 (strong alkali) is not permitted.



Note

It must be ensured that the anti-slip properties of the floor are not affected by the film-forming care product.



Note

Observe the user information provided by the manufacturer of the care product.



M68.00-0043-81

1. Application: For basic cleaning prior to final sealing.
2. Dilute the cleaning agent with clean water to a ratio of 1:5 to 1:10 as

appropriate to the level of dirt and wet the floor evenly.

Required material

Floor cleaner, make: CLAN S 700 K.
QEV111ACY87Y (1 ℓ)
QEV111AF1TVF (10 ℓ)



Note

Properties: Alkaline, non-foaming cleaning concentrate for pretreating floors in preparation for new coatings. Dissolves greases, algae, polymer dispersions and wax coatings. Permits immediate coating of cleaned floors without prior neutralisation or wiping clear.



Note

Can be used on all water-resistant surfaces, suitable for use with all coatings. Noncorrosive; does not form a glossy finish on application.

3. Allow the cleaning agent to work for 10 – 15 minutes and then scrub down the surface with a suitable wipe.

4. Remove the dissolved dirt and wipe down the surface with plenty of water to neutralise.

Instructions for exterior washes	28
Exterior washes in an automatic vehicle wash	29
Headlamps	30
Light-alloy wheels	31

Instructions for exterior washes

Instructions for exterior washes



Caution

Physical damage can be avoided by observing the following directions.

- ▶ Use a sufficient amount of fresh water.
- ▶ Dry rubbing between washing brushes and the vehicle must not be allowed to occur.
- ▶ Preclean heavily soiled components.
- ▶ Do not polish lighting equipment with commercially available care products.
- ▶ Do not use polyethylene fibres as a brush material.
- ▶ Use only brushes made with textile fibres or foam.

Exterior washes in an automatic vehicle wash

Exterior washes in an automatic vehicle wash

Exterior mirrors



M88_00-0068-01

Example illustration.

**Warning of damage to property**

Depending on the vehicle model and the nature of the washing facility, it may be necessary to fold the mirrors in or remove them entirely. To prevent damage, the directions of the washing facility manufacturer must be observed.



M88_00-0085-71

Before the bus is washed, switch off the engine and make sure that the roof hatches, driver's window and the doors are closed. Set the heating/ventilation/air-conditioning system to air-recirculation mode (Smog button). The windscreen wiper must be set to speed 0, otherwise, depending on the vehicle model, the rain sensor could be activated and trigger undesired wiping. This could result in damage to the vehicle. Before the bus is washed, fold both exterior mirrors inwards towards the windscreen either manually by means of hinge pin (1) on the mirror arm or, with electric mirrors,

using the mirror adjustment button on the instrument panel (option). Remove any attachment parts that may be fitted (e.g. satellite receiver on the roof) before the bus is washed.

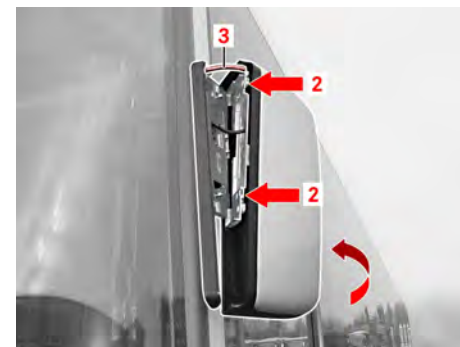

M88_00-0081-71

- ▶ Disengage the left-hand mirror from two retaining springs (2) by yanking the outside edge of the mirror housing to the rear.
- ▶ After the washing process, return the exterior mirrors to the driving position (manually or electrically, depending on vehicle equipment).

Headlamps

Headlamps



Caution

Physical damage to the plastic cover lenses of the headlamps caused by incorrect cleaning or care. Clouding, dull patches or cracks in the cover lead to diminished brightness or failure of the headlamp. This could consequently result in hazardous situations in road traffic.

- ▶ Clean only with a wet sponge and mild cleaning agent.
1. Clean the plastic cover lenses of the headlamps on a regular basis.
 2. Clean only with a wet sponge and mild cleaning agent.
 3. Do NOT use abrasive products or dry cloths, as this would scratch the surface.
 4. Do not use solvents or any cleaning agents or products containing solvents. These surfaces are NOT resistant to solvents.



Note

The headlamp cover lenses are made from plastic (polycarbonate) and painted with a clear coat.

Light-alloy wheels

**Warning**

Risk of accident from a change in vehicle driving qualities. Damaged wheel bolts or missing balance weights could cause an imbalance or even the loss of a wheel.

- ▶ Use only pH-neutral wheel cleaners that do not cause corrosion.
 - ▶ Avoid exerting strong mechanical forces during cleaning, check for the presence of wheel balance weights if necessary.
1. Observe the general safety information in the Directions for care and cleaning (→ page 4) section.
 2. Clean the light-alloy wheels regularly with warm water (preferably with a high-pressure cleaner) and a soft sponge.

 **Note**

The hard jet of water could damage the tyres.

3. For heavy soiling, use a cleaner for light-alloy wheels.

 **Note**

Unsuitable cleaners could cause corrosion to the wheel bolts, retaining springs or wheel balance weights.

 **Note**

For orders or other information, contact the manufacturer Alcoa or Speedline directly:
Alcoa Wheel Products Europe
Internet:
<http://www.alcoawheels.com>
SPEEDLINE TRUCK S.R.L.
Internet:
<http://www.speedline-truck.com>

Underbody	34
Axles with compact bearings	38

Underbody

Underbody

1. Observe the general information in the Directions for care and cleaning (→ page 4) section.

Note

Underbody refers to the entire underside of the bus, whether it may be the floor, the wheel housings or the underbody skeleton.

Note

The underbody should be inspected at regular intervals and cleaned according to the level of dirt, but at least once a year in conjunction with the annual maintenance service. This makes it possible to identify and remedy in good time any part of the underbody protection coating that may be flawed or damaged.

Cleaning the underbody with a hot-water high-pressure cleaner

Note

Remove the protective cladding on the underbody and clean it separately.

Note

The underbody is coated to protect it from corrosion and stone impact. Clean as carefully as possible to avoid washing off or damaging the good protective layers. The spraying distance should be adjusted to suit the water temperature, water pressure and the spray nozzle.

Note

The underbody should be washed mainly with clean water. Save the use of a cleaning agent for dirt that proves very difficult to remove.



Environmental protection

Observe waste water regulations. Clean the bus only in an appropriately equipped cleaning bay.

1. Carry out a full inspection of the underbody, paying particular attention to damage and to layers that are abnormally saturated and discoloured with dirt.

Note

Some defects are evident only when the underbody is dirty, all trace of which may disappear after cleaning. For example, it may be possible to identify leaking unions on oil, fuel and coolant lines and reservoirs as well as leak points on assemblies from the level of dirt saturation and concealed corrosion in discoloured layers. Flaws and defects that are identified should be rectified after cleaning.

2. Use a hot-water high-pressure cleaner in accordance with the manufacturer's instructions.

Required material	
Hot-water high-pressure cleaner	

3. Mix the cleaning agent and water as required in accordance with the manufacturer's instructions or add an appropriate concentration to the designated container on the cleaning device.

Required material	
RM 55 A 002 986 67 71	

4. Attach a flat-spray nozzle to the spray lance or, if you are using a variable-pattern nozzle, adjust it to the appropriate spray angle.

Reference values	
Spray angle of the flat jet nozzle at least	25°

 **Note**

The nozzle spray angle is crucial to cleaning performance. The wider the nozzle spray angle, the gentler the cleaning effect.

5. On the high-pressure cleaner, select the appropriate water pressure, water temperature and detergent delivery rate.

Reference values	
Maximum permissible water pressure	60 bar
Maximum permissible water temperature	60 °C

 **Warning of damage to property**

An excessive water pressure or temperature or an unsuitable spray nozzle could destroy the protective coating on the underbody or damage vehicle components beyond repair.



Warning of damage to property

The detergent concentration and delivery rate should be adjusted to the type and amount of dirt in the area to be cleaned. Excessive detergent may result in damage.

6. Switch on the water spray, aiming the nozzle either at the ground or into an open space and then direct the spray towards the surface to be cleaned. Maintain the maximum permissible spray distance.

Reference values	
Spray distance from the object at least	30 cm

7. Spray the layer of dirt on the underbody thoroughly with the water jet.

 **Note**

Leave the sprayed water to work. Repeat sprays may be required, depending on the amount of dirt.

Underbody

Note

Pay particular attention to dirt deposits in corners, cavities, wheel housings and on lines, as well as between the ramp and underbody.

8. Rinse off the layer of dirt on the underbody using a high-pressure water jet.

Note

Only direct the high-pressure jet at seams, gaps or cavities for brief periods. Water that penetrates deep into the structure of bus could promote concealed corrosion accelerated by the effects of the cleaning agent and lead to the weakening of load-bearing parts of the skeleton.

9. Shut off the delivery of detergent and rinse down all areas of the underbody with water.

Note

The cleaning agent must not be left to dry. Residue from cleaning products could permanently damage surface finishes and moving parts.

10. Clean out openings and condensate drain holes in pipes, body profiles and cavities manually, e.g. using a thin, pointed object.

Note

Do not wash out drainage openings using a pressure cleaner. These openings ensure that condensate and any water that penetrates these areas during cleaning is able to drain out and dry off.

11. Leave the underbody to dry naturally.
12. To finish, carry out a visual inspection of the underbody.

Note

During the visual inspection, look over complete and undamaged protective coatings (wax and stone chip protection) in particular and look out for corrosion damage. Also check for damage to tyres, suspension air bags, brake hoses, seal cups and bearings for moving parts, as well as electrical lines and their connections.

Note

Flaws and defects must be repaired to a professional standard, bearings and joints must be lubricated. Damaged tyres, suspension air bags and pressure hoses must be replaced with new ones.

13. Test-drive the bus, and test the brakes and level control system.



Note

Flaws must be repaired to a professional standard.

Axles with compact bearings

Axles with compact bearings

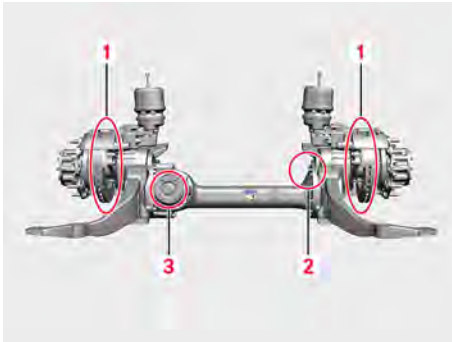

M35.15-0023-71

- Observe the general safety information in the Directions for care and cleaning (→ page 4) section.



Warning of damage to property

Do not use any jet wash facility that would subject areas (1), (2) and (3) to extreme amounts of water, e.g. where the underbody washes are too intensive.

Interior/exterior 40



M54.00-2004-71

Warning

Risk of injury from inadvertent activation of the windscreen wiper system. For cleaning work at the windscreen:

- ▶ Switch the battery isolating switch (O1S01) to OFF.



Warning of damage to property

Unsuitable cleaning products could cause damage to passenger seats, attachment parts and painted surfaces.



Note

The user information issued by the manufacturer of the cleaning agent must be strictly observed.

▶ **Cleaning agent**

Required material
“ULMIL” glass cleaner QE1111ADJELY

- B**
- Bottom**
- Axles with compact bearings 38
 - Underbody 34
- D**
- Directions for care and cleaning**
- Directions for care and cleaning 4
- E**
- Exterior**
- Automatic vehicle wash 29
 - Headlamps 30
 - Instructions, advice 28
 - Light-alloy wheels 31
- I**
- Interior**
- Ceiling, TC 500 22
 - Ceilings 21
 - Covers and upholstery 8
 - Fabric covers 10
 - Flat-weave fabric upholster-
ies 13
 - Floor coverings 24
 - Leather covers 15
 - Micro-fibre covers 19
 - Needle-punched nonwoven fab-
rics 18
 - Stain types, treatment advice 9
- W**
- Windows**
- Interior/exterior 40